

WK4.5T-10/S2503

RFID Cable Economy Version – Connection Cable

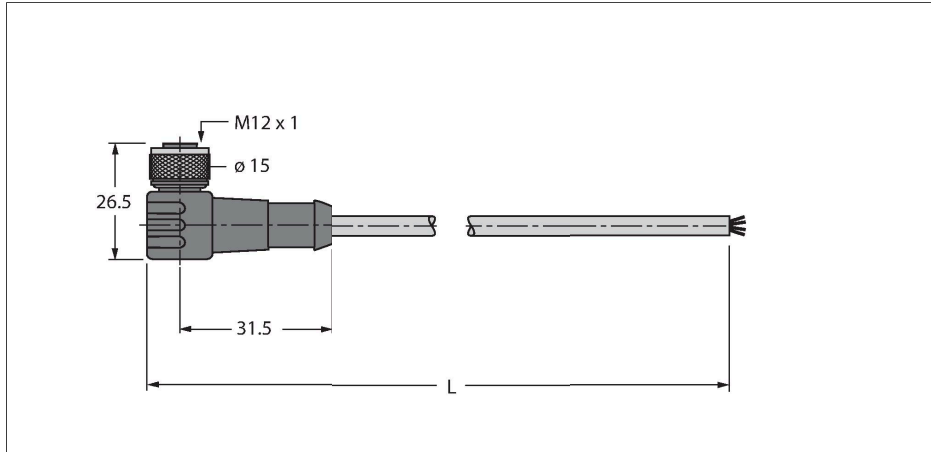

Features



- 4-core, AWG 19/24 (data cable), AWG 19/22 (supply cable)
- Jacket material: PUR, color: black
- Halogen- and LABS-free
- Shield: Aluminum foil, tinned copper braid
- Jacket diameter: 6.7 mm
- Suitable for drag chain use, oil-resistant, flexible
- Cable UL Style 20549
- Open end
- Cable length: 10 m

Cable Cross-Section

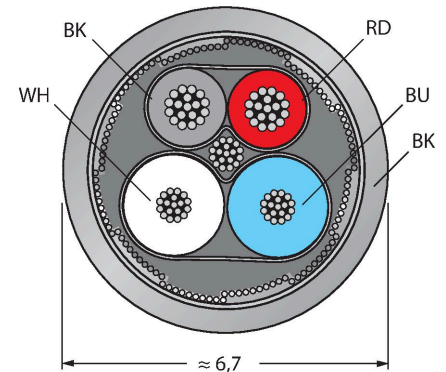

Contact assignment

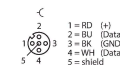

Technical data

Type	WK4.5T-10/S2503
ID	7030348
Connector A	Female, M12 × 1, Angled, A-coded
Number of Pins	5
Contacts	Metal, CuZn, Gold-plated
Contact carriers	Plastic, TPU, Black
Connector body	Plastic, TPU, Black
Coupling nut/screw	Brass, CuZn-Ni, Nickel-plated
Seal	Plastic, FPM/FKM
Tightening torque (range)	0.6 ... 1 Nm (observe max. torque of mating connector!)
Mechanical lifespan	> 100 Mating cycles
Pollution degree	3
Protection class	IP67, Only in screwed condition
Cable	
Cable diameter	Ø 6.7 mm
Cable length	10 m
Cable jacket	PUR, Black
Shielding	yes
Core cross-section	2 x 0.25 mm ²
Cable conductor cross-section	2x 0.34 mm ²
Core colors	Power: RD, BK, Data: WH, BU
Electrical properties at +20 °C	
Rated voltage	60 V
Current	4 A
DC resistance (loop)	164 Ω/km

Technical data

Mechanical and chemical properties	
Bending radius (flexible use)	$\geq 10 \times \varnothing$
Bending cycles	≥ 1 million
Ambient temperature range (stationary)	-30 °C...+80 °C
Ambient temperature range (In motion)	-25 °C...+80 °C
Other Features	
Qualified for drag chain use	yes
Approvals	Cable UL Style 20549